

承 认 书

ACCEPT SHEET

文件编号: EN-QS-1-A-590
 NO. _____
 客户名称: _____
 Customer: _____
 客户料号: _____
 Part.No.: _____
 品 名: _____
 Description SMD 5050
 规 格: _____
 Model: BD50-23RCS/A
 送样日期: _____
 Day: _____

客户承认章/签	核准	制定
CUSTOMER APPROVED	APPROVED	ISSUED
	何湘辉	卢淑芬



BAI DE OPTO-ELECTRONICS CO.,LTD.

Address: Lingdong Industrial Zone, Dagang Town, PanYu,
 Guangzhou Guangdong, China

Tel: +86-20-84931111-121/169; Fax: 020-34998271

[Http://www.baide.biz](http://www.baide.biz)

◆ **Features**

- * High brightness surface mount technology.
- * Emitting view angle 120°
- * Suitable for all SMT assembly method.
- * IR reflow soldering and vapor phase reflow soldering.
- * For outdoor and indoor display, backlight application.

◆ **Package Dimensions**

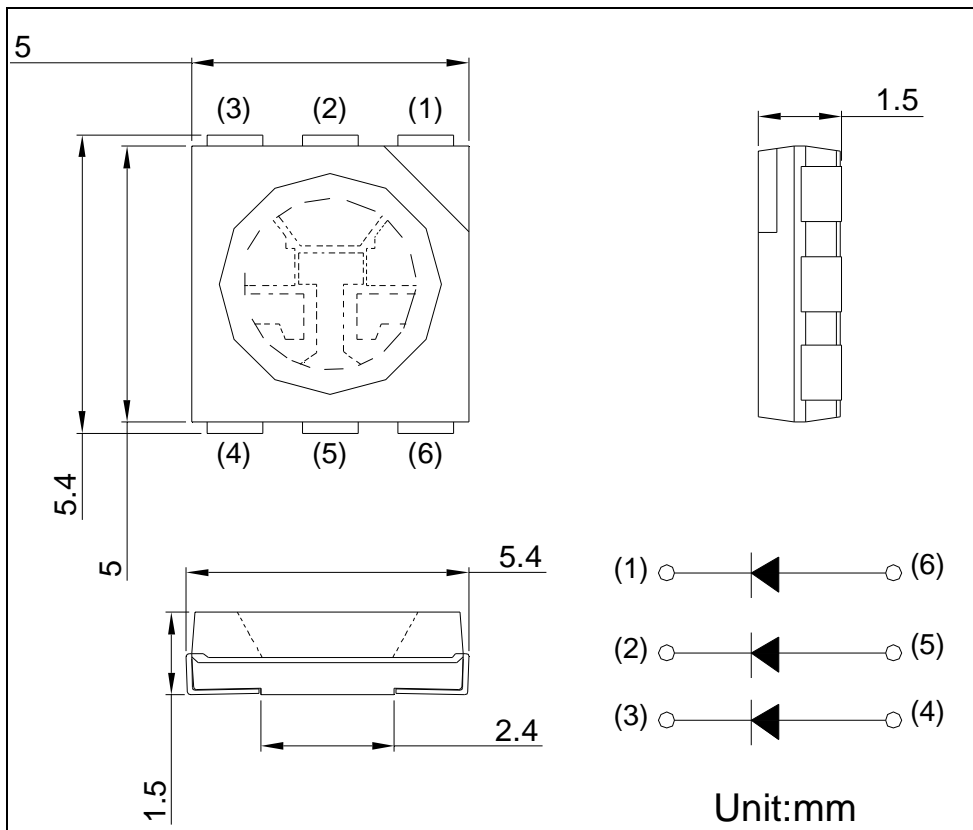

Notes:

1. All dimensions are in mm.
2. Tolerance is ± 0.25 mm unless otherwise noted.
3. Lead spacing is measured where the leads emerge from the package.

◆ **Description**

Model No.	Material	Emitted	Lens Color
BD50-23RCS/A	AllnGaP/GaN	Red	Water

◆ Absolute Maximum Ratings ($T_A=25^{\circ}\text{C}$)

Parameter	Symbol	Rating	Unit
Power Dissipation	P_D	200	mW
Forward Current (DC)	I_F	60	mA
Peak Forward Current *	I_{FP}	100	mA
Reverse Voltage	V_R	5.0	V
Operation Temperature Range	T_{op}	-25to+85	$^{\circ}\text{C}$
Storage Temperature Range	T_{stg}	-40to+100	$^{\circ}\text{C}$
Soldering Temperature	260 $^{\circ}\text{C}$ /5sec		

* Pulse width \leq 0.1msec Duty Ratio \leq 1/10

◆ Electrical and Optical Characteristics ($T_A=25^{\circ}\text{C}$)

Parameter	Test Condition	Symbol	Min	Typ	Max	Unit
Forward Voltage(v_F)	$I_F=60\text{mA}$	V_F	1.8		2.0	V
			2.0		2.2	
			2.2		2.4	
View Angle	$I_F=60\text{mA}$	2θ 1/2		120		deg
Chromaticity	$I_F=60\text{mA}$	λ_{dom}	620		630	nm
Reverse Current	$V_R=-5\text{V}$	I_R			2	μA
Luminous Intensity(I_V)	$I_F=60\text{mA}$	I_V	1600		1900	mcd
			1900		2300	
			2300		2700	

Notes:

- 1.The dominant Wavelength, λ_{dom} is derived from the CIE chromaticity diagram and represents the single wavelength which define the color of the device.
2. 2θ 1/2 is the off-axis angle where the luminous intensity is one half the on-axis intensity.
- 3.Luminous intensity is measured by BAI DE TECH.'S equipment on TopLED in the same lot.

◆ Typical Electrical/Optical Characteristic Curves (If=60mA; TA=25°C)

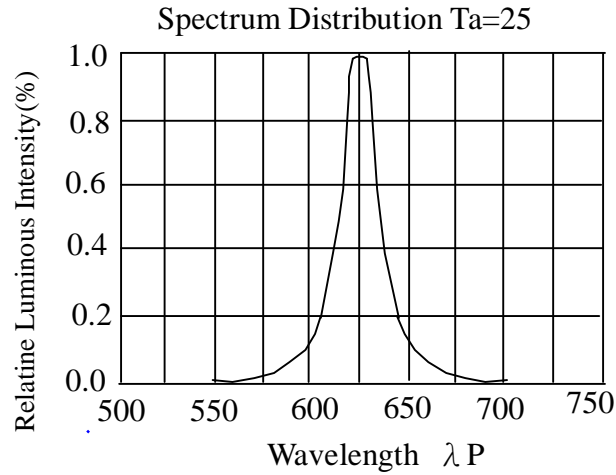

Forward Current vs. Forward Voltage

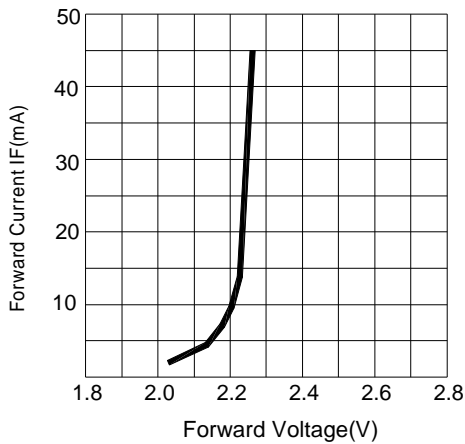

Relative Luminous Intensity vs. Forward Current

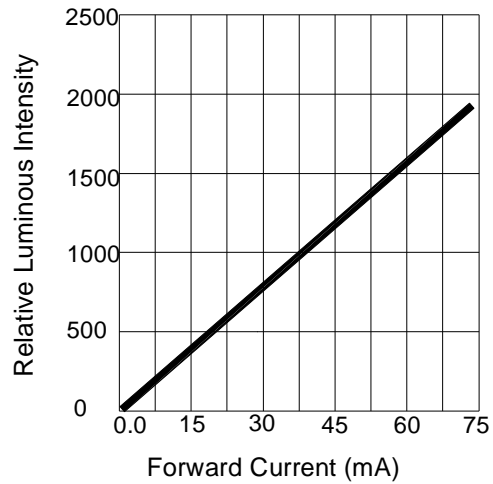

Ambient Temperature VS. Forward Current

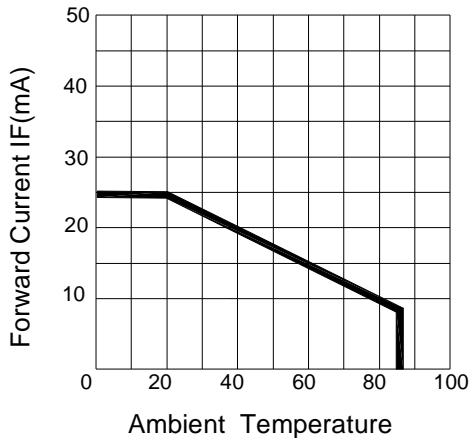

Radiation Diagram

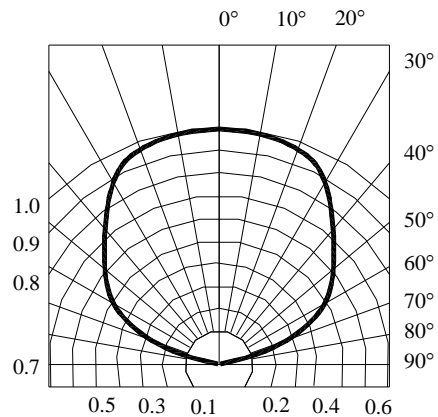

◆ PRECAUTION IN USE

Recommended solder pad:

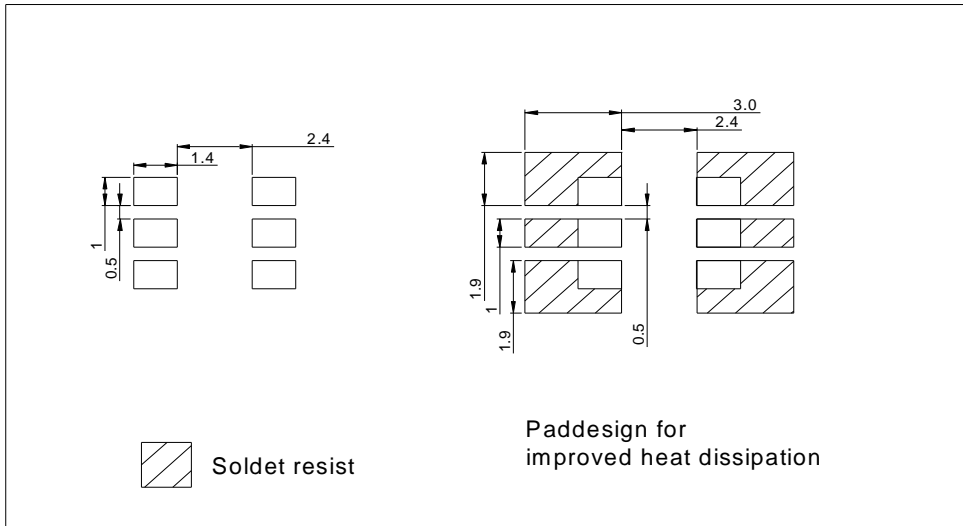

Vapor Phase Reflow Soldering Profile:

For Lead Solder:

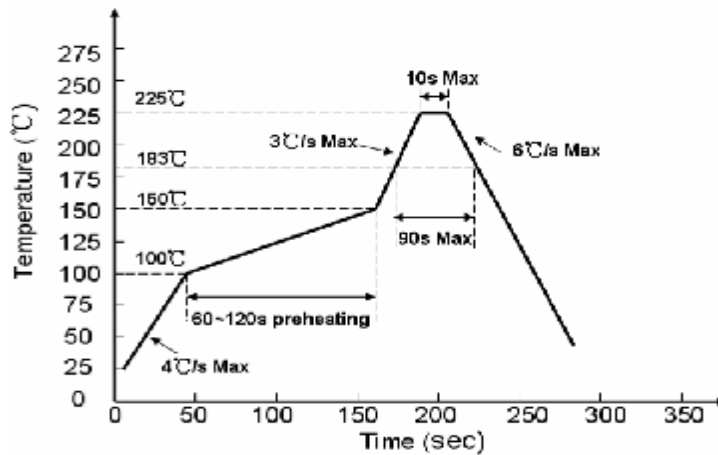

For Lead Free Solder:

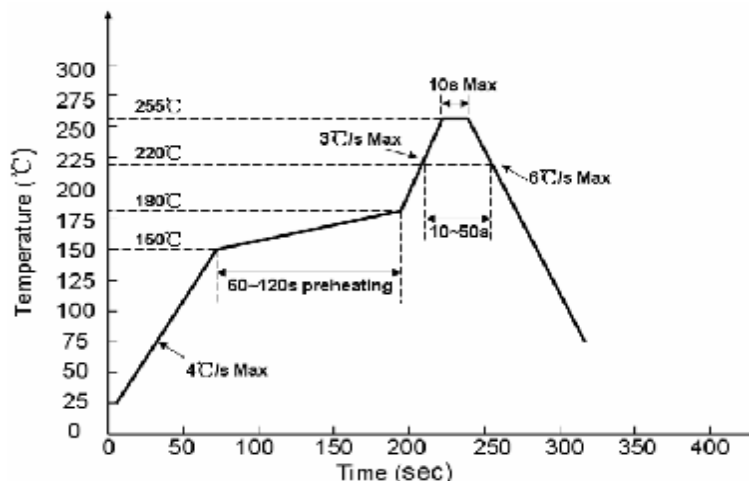

◆ Dimensions for Tape

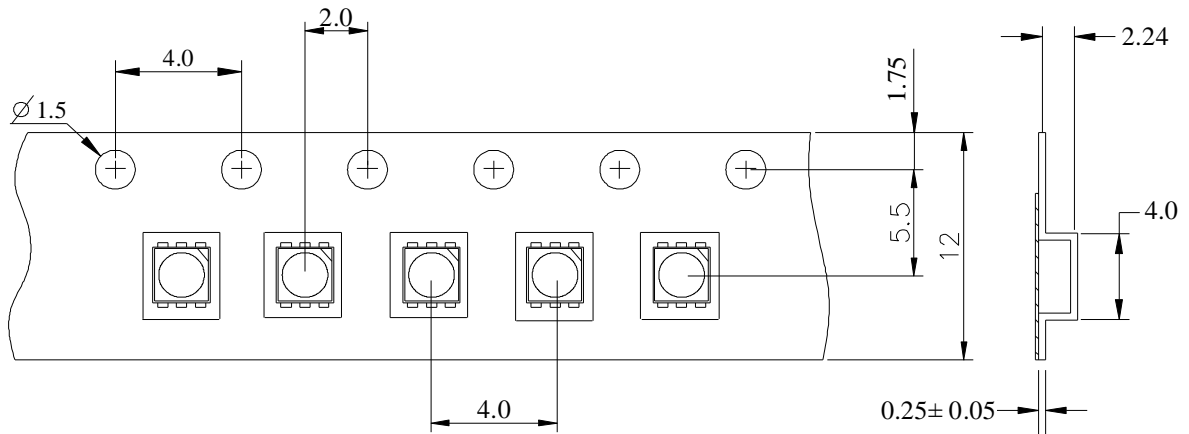

◆ Dimensions for Reel

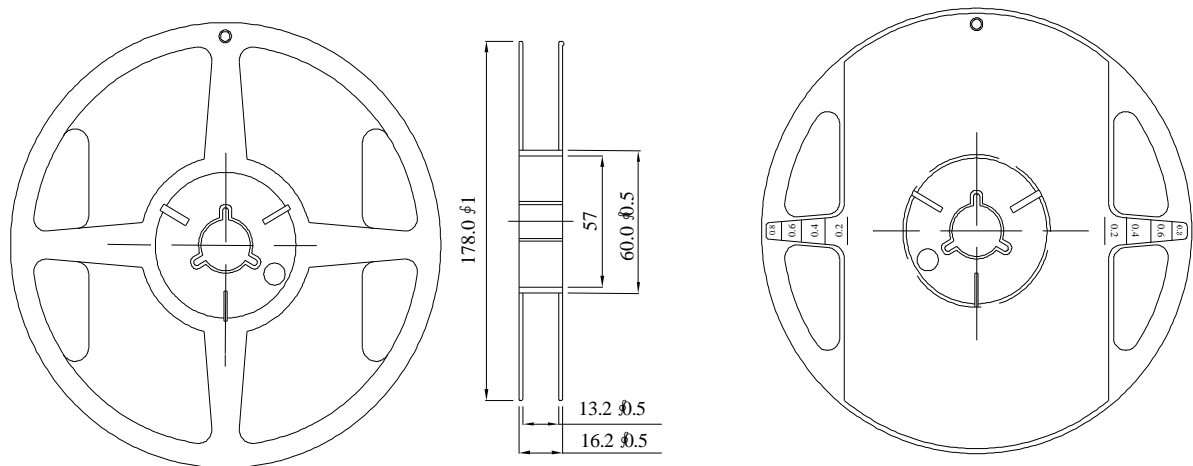

Notes:

1. All dimensions are in mm, tolerance is ± 2.0 mm unless otherwise noted.
2. Specifications are subject to change without notice.

◆ Packing

Notes:

- 1.All dimensions are in mm, tolerance is ± 2.0 mm unless otherwise noted.
- 2.Specifications are subject to change without notice.

REEL
QUANTITY: 1,000 PCS

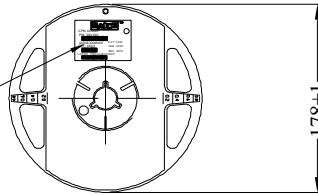
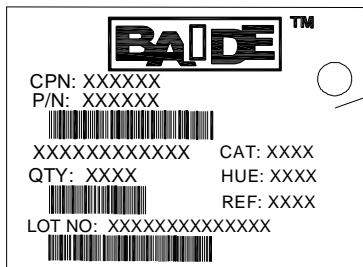

湿气敏感材料
MOISTURE SENSITIVE DEVICES

1. 在5°C-30°C密封储藏, 1年有效。
Shelf life in sealed bag : 12 months at 5°C~30°C .
2. 开封后需在168小时内使用。
Devices have to be mounted within 168 hours after this bag is opened .

BAG
QUANTITY: 1,000 PCS

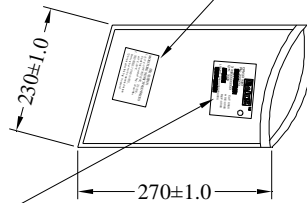

INSIDE BOX
QUANTITY: 4 BAGS
TOTAL: 4,000 PCS

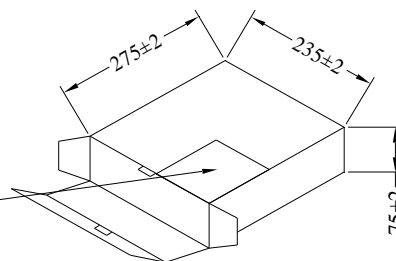
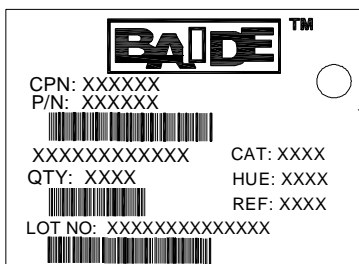

◆ Reliability Test:

Classification	Test Item	Test Condition	Reference Standard	Reference Standard
Endurance Test	Operation Life	Ta= Under Room Temperature As Per Data Sheet Maximum Rating	1000HRS (-24HRS,+72HRS)*@20mA	MIL-STD-750D:1026 MIL-STD-883D:1005 JIS C 7021:B-1
	High Temperature, High Humidity Storage	IR-Reflow In-Board, 2 Times Ta= 65±5°C,RH= 90~95%	240HRS±2HRS	MIL-STD-202F:103B JIS C 7021:B-11
	High Temperature Storage	Ta= 105±5°C	1000HRS (-24HRS,+72HRS)	MIL-STD-883D:1008 JIS C 7021:B-10
	Low Temperature Storage	Ta= -55±5°C	1000HRS (-24HRS,+72HRS)	JIS C 7021:B-12
Environmental Test	Temperature Cycling	105°C ~ 25°C ~ -55°C ~ 25°C 30mins 5mins 30mins 5mins	10 Cycles	MIL-STD-202F:107D MIL-STD-750D:1051 MIL-STD-883D:1010 JIS C 7021:A-4
	Thermal Shock	IR-Reflow In-Board, 2 Times 85 ± 5°C ~ -40°C ± 5°C 10mins 10mins	10 Cycles	MIL-STD-202F:107D MIL-STD-750D:1051 MIL-STD-883D:1011
	Solder Resistance	T.sol= 260 ± 5°C	10 ± 1secs	MIL-STD-202F:210A MIL-STD-750D:2031 JIS C 7021:A-1
	IR-Reflow Normal Process	Ramp-up rate(183°C to Peak) +3°C/ second max Temp. maintain at 125(±25)°C 120 seconds max Temp. maintain above 183°C 60-150 seconds Peak temperature range 235°C+5/-0°C Time within 5°C of actual Peak Temperature (tp) 10-30 seconds Ramp-down rate +6°C/second max	-----	MIL-STD-750D:2031.2 J-STD-020C
	IR-Reflow Pb Free Process	Ramp-up rate(217°C to Peak) +3°C/ second max Temp. maintain at 175(±25)°C 180 seconds max Temp. maintain above 217°C 60-150 seconds Peak temperature range 260°C+0/-5°C Time within 5°C of actual Peak Temperature (tp) 20-40 seconds Ramp-down rate +6°C/second max	-----	MIL-STD-750D:2031.2 J-STD-020C
Solderability	T.sol= 235 ± 5°C Immersion rate 25±2.5 mm/sec Coverage ≧ 95% of the dipped surface	Immersion time 2±0.5 sec	MIL-STD-202F:208D MIL-STD-750D:2026 MIL-STD-883D:2003 IEC 68 Part 2-20 JIS C 7021:A-2	

◆ Application

1. A LED is a current-operated device. The slight shift of voltage will cause big change of current, which will damage LEDs. Customer should use resistors in series for the Over-Current-Proof.
2. In order to ensure intensity uniformity on multiple LEDs connected in parallel in an application, it is recommended to use individual resistor separately, as shown in Circuit A below. The brightness of each LED shown in Circuit B might appear difference due to the differences in the I-V characteristics of those LEDs.

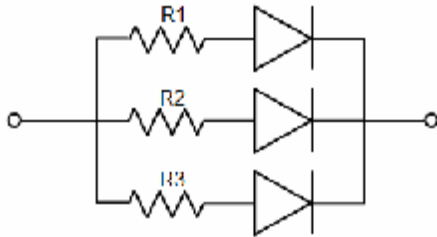

Circuit model A

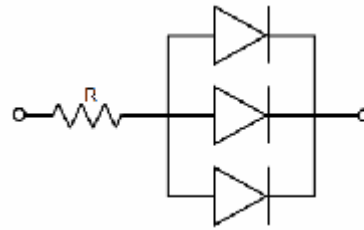

Circuit model B

3. High temperature may reduce LEDs' intensity and other performances, so keeping it away from heat source to get good performance is necessary.

Storage

1. Before opening original package, it is recommended to store them in the following environment:
 Temperature: 5°C~30°C Humidity: 85%RH max.
2. After opening original package, the storage ambient for the LEDs should be in 5~30°C temperature and 60% or less relative humidity.
3. In order to avoid moisture absorption, it is recommended that the LEDs that out of the original package should be stored in a sealed container with appropriate desiccant, or in desiccators with nitrogen ambient.
4. The LEDs should be used within 12hrs after opening the package. Once been mounted, soldering should be quick.
5. If the moisture absorbent material (silica gel) has faded away or the LEDs stored out of original package for more than 12hrs, baking treatment should be performed using the conditions: 60°C at least 24 hours.

ESD (Electrostatic Discharge)-Protection

A LED (especially the Blue、White and Green product) is an ESD sensitive component, and static electricity or power surge will damage the LED. ESD-damaged LEDs will exhibit abnormal characteristics such as high reverse leakage current, low forward voltage, or “no light-up” at low currents, etc.

Some advice as below should be noticed:

1. A conductive wrist strap or anti-electrostatic glove should be worn when handling these LEDs.
2. All devices, equipment, machinery, work tables and storage racks, etc. must be properly grounded.
3. Use anti-static package or boxes to carry and storage LEDs. And ordinary plastic package or boxes is forbidden to use.
4. Use ionizer to neutralize the static charge during handling or operating.
5. All surfaces and objects within 1 ft close to LEDs measure less than 100V.

Cleaning

Use alcohol-based cleaning solvents such as IPA (isopropyl alcohol) to clean LEDs if necessary.

Soldering

1. Soldering condition refer to the draft “Soldering Profile Suggested” on page 1.
2. Reflow soldering should not be done more than 2 times.
3. Manual soldering is only suggested on repair and rework. The maximum soldering temperature should not exceed 300°C within 3 sec. And the maximum capacity of soldering iron is 30W in power.
4. During the soldering process, do not touch the lens at high temperature.
5. After soldering, any mechanical force on the lens or any excessive vibration shall not be accepted to apply, also the circuit board shall not be bent as well.

Others

1. The LEDs described here are intended to be used for ordinary electronic equipment (such as office equipment, communication equipment and household applications). Consult Baide’s Sales in advance for the applications in which exceptional reliability is required, particularly when the failure or malfunction of the LEDs may directly jeopardize life or health. (such as in aviation, transportation, traffic control equipment, medical and life support systems and safety devices).
2. The light output from the high luminous intensity LEDs may cause injury to human eyes when viewed directly.
3. The appearance and specifications of the product may be modified for improvement without prior notice.