

# BZX84C2V4 - BZX84C39

## 350mW Surface Mount Zener Diode

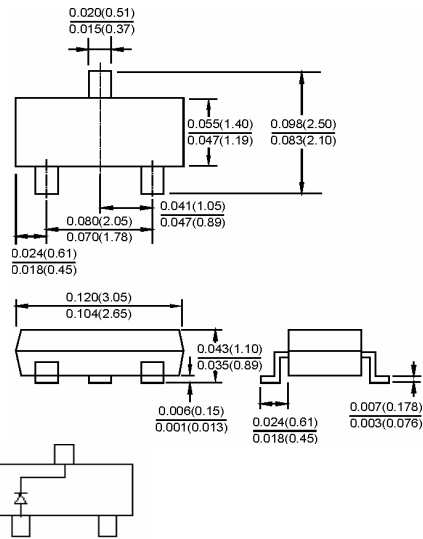

### SOT-23



### Features

- ✧ Planar die construction
- ✧ 350 mW power dissipation
- ✧ Zener voltages from 2.4V – 39V
- ✧ Ideally suited for automated assembly processes

### Mechanical Data

- ✧ Case: SOT-23, Molding plastic
- ✧ Case material – UL Flammability rating 94V-0
- ✧ Moisture sensitivity: Level 1 per J-STD-020A
- ✧ Terminals: Solderable per MIL-STD-202, Method 208
- ✧ Polarity: See diagram
- ✧ Lead free plating
- ✧ Marking: Marking Code
- ✧ Weight: 0.008 grams (approx.)

### Maximum Ratings and Electrical Characteristics

Rating at 25 °C ambient temperature unless otherwise specified.

Type Number	Symbol	Value	Units
Forward Voltage @ IF = 10mA	$V_F$	0.9	V
Power Dissipation (Note 1)	$P_d$	350	mW
Thermal Resistance Junction to Ambient Air (Note 1)	$R_{\theta JA}$	357	K /W
Operating and Storage Temperature Range	$T_J, T_{STG}$	-65 to + 150	°C

- Notes:
1. Valid Provided that Device Terminals are Kept at Ambient Temperature.
  2. Tested with Pulses. Period = 5ms, Pulse Width = 300us.
  3. f = 1KHz.

ELECTRICAL CHARACTERISTICS (TA=25°C unless otherwise noted)

Type Number (Note 1)	Marking Code	Zener Voltage Range (Note 2)				Maximum Zener Impedance (Note 3)			Maximum Reverse Current		Typical Temperature Coefficient @ IZT mV / °C	
		Vz @ Izt			IzT	ZZT @ IZT Ohms	ZZK @ IZK		IR uA	VR V	Min	Max
		Nom (V)	Min (V)	Max (V)	mA		Ohms	mA				
BZX84C2V4	Z11	2.4	2.2	2.6	5.0	100	600	1.0	50	1.0	-3.5	0
BZX84C2V7	Z12	2.7	2.5	2.9	5.0	100	600	1.0	20	1.0	-3.5	0
BZX84C3V0	Z13	3.0	2.8	3.2	5.0	95	600	1.0	10	1.0	-3.5	0
BZX84C3V3	Z14	3.3	3.1	3.5	5.0	95	600	1.0	5.0	1.0	-3.5	0
BZX84C3V6	Z15	3.6	3.4	3.8	5.0	90	600	1.0	5.0	1.0	-3.5	0
BZX84C3V9	Z16	3.9	3.7	4.1	5.0	90	600	1.0	3.0	1.0	-3.5	0
BZX84C4V3	Z17	4.3	4.0	4.6	5.0	90	600	1.0	3.0	1.0	-3.5	0.0
BZX84C4V7	Z1	4.7	4.4	5.0	5.0	80	500	1.0	3.0	2.0	-3.5	0.2
BZX84C5V1	Z2	5.1	4.8	5.4	5.0	60	480	1.0	2.0	2.0	-2.7	1.2
BZX84C5V6	Z3	5.6	5.2	6.0	5.0	40	400	1.0	1.0	2.0	-2.0	2.5
BZX84C6V2	Z4	6.2	5.8	6.6	5.0	10	150	1.0	3.0	4.0	0.4	3.7
BZX84C6V8	Z5	6.8	6.4	7.2	5.0	15	80	1.0	2.0	4.0	1.2	4.5
BZX84C7V5	Z6	7.5	7.0	7.9	5.0	15	80	1.0	1.0	5.0	2.5	5.3
BZX84C8V2	Z7	8.2	7.7	8.7	5.0	15	80	1.0	0.7	5.0	3.2	6.1
BZX84C9V1	Z8	9.1	8.5	9.6	5.0	15	100	1.0	0.5	6.0	3.8	7.0
BZX84C10	Z9	10	9.4	10.6	5.0	20	150	1.0	0.2	7.0	4.5	8.0
BZX84C11	Y1	11	10.4	11.6	5.0	20	150	1.0	0.1	8.0	5.4	9.0
BZX84C12	Y2	12	11.4	12.7	5.0	25	150	1.0	0.1	8.0	6.0	10.0
BZX84C13	Y3	13	12.4	14.1	5.0	30	170	1.0	0.1	8.0	7.0	11.0
BZX84C15	Y4	15	13.8	15.6	5.0	30	200	1.0	0.1	10.5	9.2	13.0
BZX84C16	Y5	16	15.3	17.1	5.0	40	200	1.0	0.1	11.2	10.4	14.0
BZX84C18	Y6	18	16.8	19.1	5.0	45	225	1.0	0.1	12.6	12.4	16.0
BZX84C20	Y7	20	18.8	21.2	5.0	55	225	1.0	0.1	14.0	14.4	18.0
BZX84C22	Y8	22	20.8	23.3	5.0	55	250	1.0	0.1	15.4	16.4	20.0
BZX84C24	Y9	24	22.8	25.6	5.0	70	250	1.0	0.1	16.8	18.4	22.0
BZX84C27	Y10	27	25.1	28.9	2.0	80	300	0.5	0.1	18.9	21.4	25.3
BZX84C30	Y11	30	28	32	2.0	80	300	0.5	0.1	21.0	24.4	29.4
BZX84C33	Y12	33	31	35	2.0	80	325	0.5	0.1	23.1	27.4	33.4
BZX84C36	Y13	36	34	38	2.0	90	350	0.5	0.1	25.2	30.4	37.4
BZX84C39	Y14	39	37	41	2.0	130	350	0.5	0.1	27.3	33.4	41.2

- Notes: 1. Valid provided that device terminals are kept at ambient temperature.  
2. Tested with pulses, 300us pulse width, period = 5ms.  
3. f = 1KHz.

### RATINGS AND CHARACTERISTIC CURVES (BZX84C2V4 - BZX84C39)

FIG.1- POWER DERATING CURVE

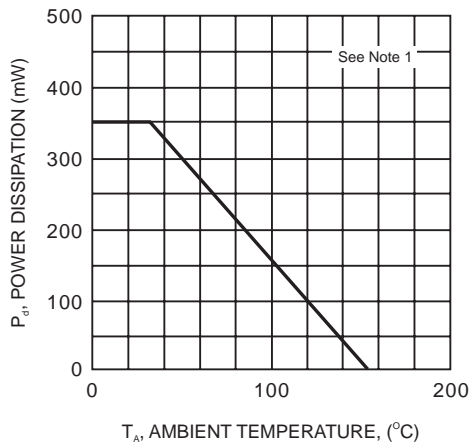

FIG.2- ZENER BREAKDOWN CHARACTERISTICS

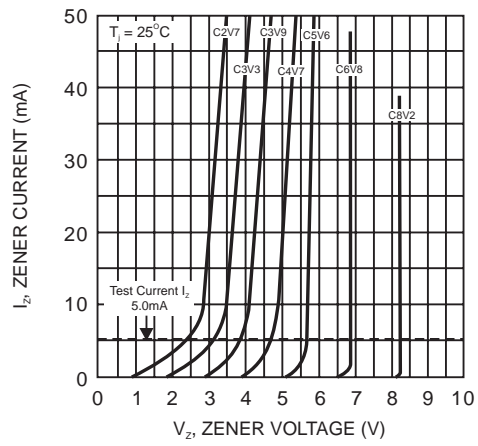

FIG.3- ZENER BREAKDOWN CHARACTERISTICS

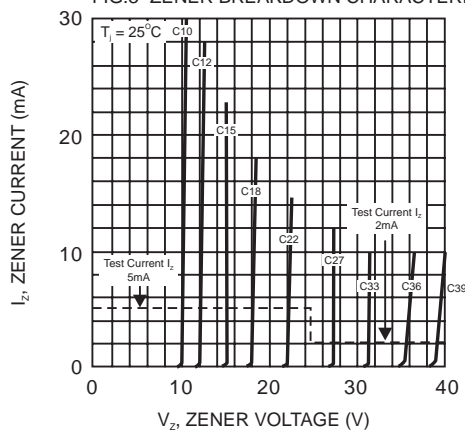

FIG.4- JUNCTION CAPACITANCE VS NOMINAL ZENER VOLTAGE

